

ARTICLE 250

Grounding and Bonding

INTRODUCTION TO ARTICLE 250—GROUNDING AND BONDING

No other article can match Article 250 for misapplication, violation, and misinterpretation. Terminology used in this article has been a source for much confusion, but that has improved during the last few *NEC* revisions. It's very important to understand the difference between grounding and bonding in order to correctly apply the provisions of Article 250. Pay careful attention to the definitions that apply to grounding and bonding both here and in Article 100 as you begin the study of this important article. Article 250 covers the grounding requirements for providing a path to the earth to reduce overvoltage from lightning, and the bonding requirements for a low-impedance fault current path back to the source of the electrical supply to facilitate the operation of overcurrent devices in the event of a ground fault.

Over the past five Code cycles, this article was extensively revised to organize it better and make it easier to understand and implement. It's arranged in a logical manner, so it's a good idea to just read through Article 250 to get a big picture view—after you review the definitions. Next, study the article closely so you understand the details. The illustrations will help you understand the key points.

PART I. GENERAL

250.1 Scope. Article 250 contains the following grounding and bonding requirements:

- (1) What systems and equipment are required to be grounded.
- (3) Location of grounding connections.
- (4) Types of electrodes and sizes of grounding and bonding conductors.
- (5) Methods of grounding and bonding.

250.2 Definitions.

Bonding Jumper, Supply-Side. A conductor on the supply side or within a service or separately derived system to ensure the electrical conductivity between metal parts required to be electrically connected. **Figures 250–1 and 250–2**

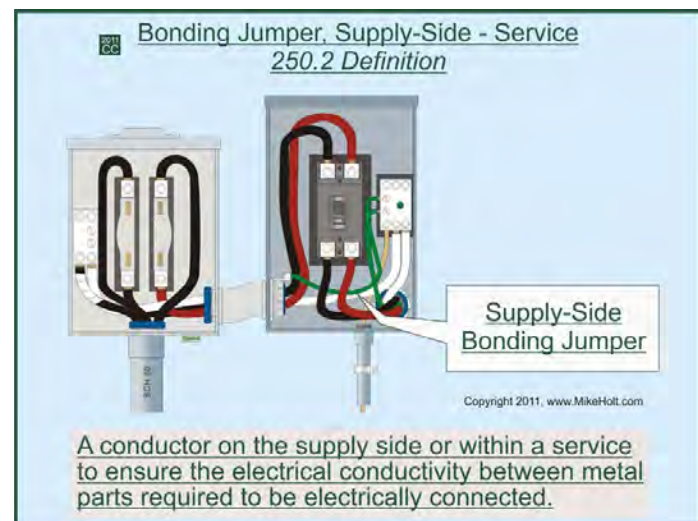

Figure 250–1

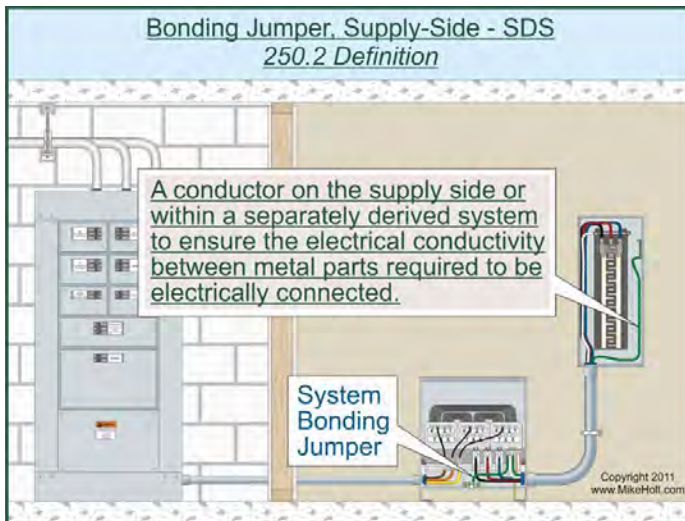

Figure 250-2

Effective Ground-Fault Current Path. An intentionally constructed low-impedance conductive path designed to carry fault current from the point of a ground fault on a wiring system to the electrical supply source. **Figure 250-3**

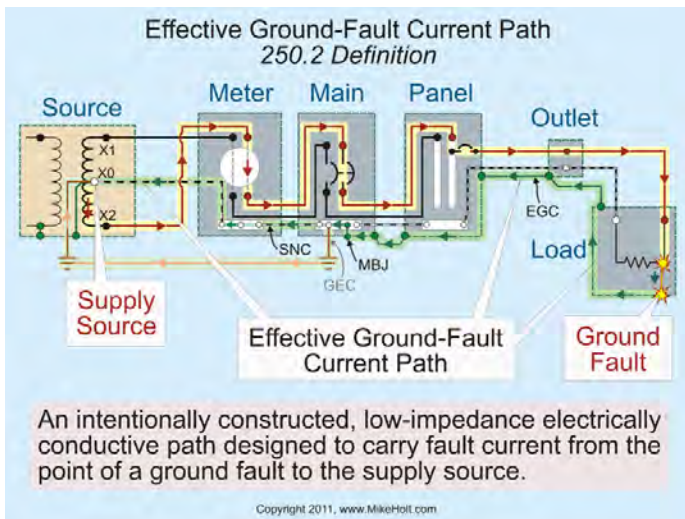

Figure 250-3

Author's Comment: In **Figure 250-3**, EGC represents the equipment grounding conductor [259.118], MBI represents the main bonding jumper, SNC represents the service neutral conductor (grounded service conductor), GEC represents the grounding electrode conductor.

The current path shown between the supply source grounding electrode and the grounding electrode at the service main shows that some current will flow through the earth but the earth is not part of the effective ground-fault current path.

The effective ground-fault current path is intended to help remove dangerous voltage from a ground fault by opening the circuit overcurrent device. **Figure 250-4**

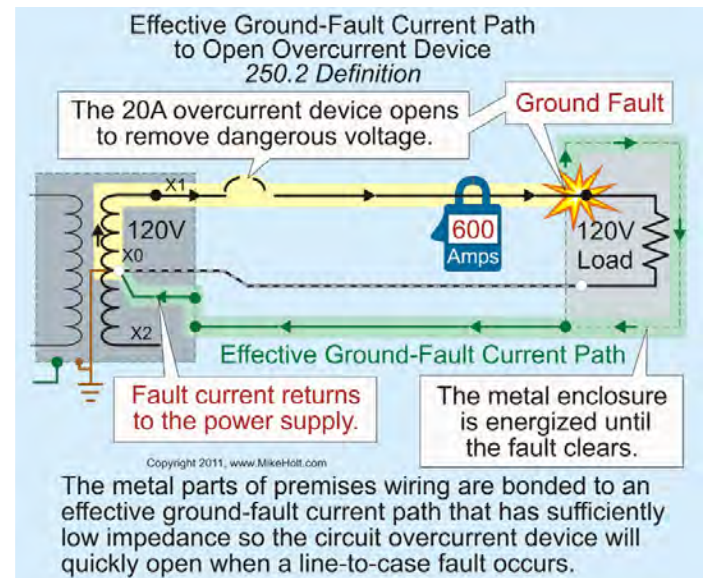

Figure 250-4

Ground-Fault Current Path. An electrically conductive path from a ground fault to the electrical supply source.

Note: The ground-fault current path could be metal raceways, cable sheaths, electrical equipment, or other electrically conductive materials, such as metallic water or gas piping, steel-framing members, metal ducting, reinforcing steel, or the shields of communications cables. **Figure 250-5**

Author's Comment: The difference between an "effective ground-fault current path" and a "ground-fault current path" is the effective ground-fault current path is "intentionally" constructed to provide a low-impedance fault current path to the electrical supply source for the purpose of clearing a ground fault. A ground-fault current path is all of the available conductive paths over which fault current flows on its return to the electrical supply source during a ground fault.

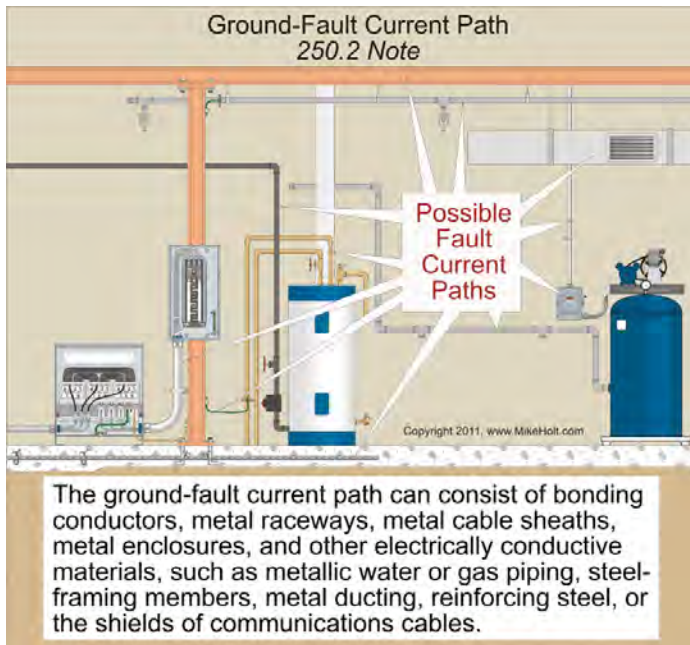

Figure 250-5

250.4 General Requirements for Grounding and Bonding.

(A) Solidly Grounded Systems.

(1) Electrical System Grounding. Electrical power systems, such as the secondary winding of a transformer are grounded (connected to the earth) to limit the voltage induced by lightning, line surges, or unintentional contact by higher-voltage lines. **Figure 250-6**

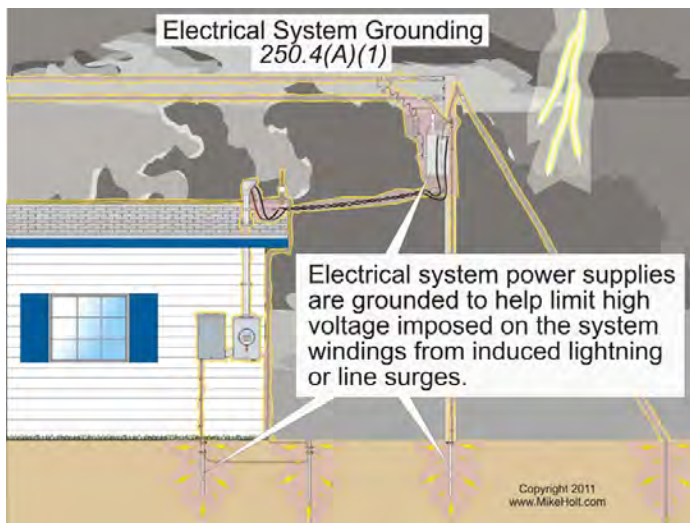

Figure 250-6

Author's Comment: System grounding helps reduce fires in buildings as well as voltage stress on electrical insulation, thereby ensuring longer insulation life for motors, transformers, and other system components. **Figure 250-7**

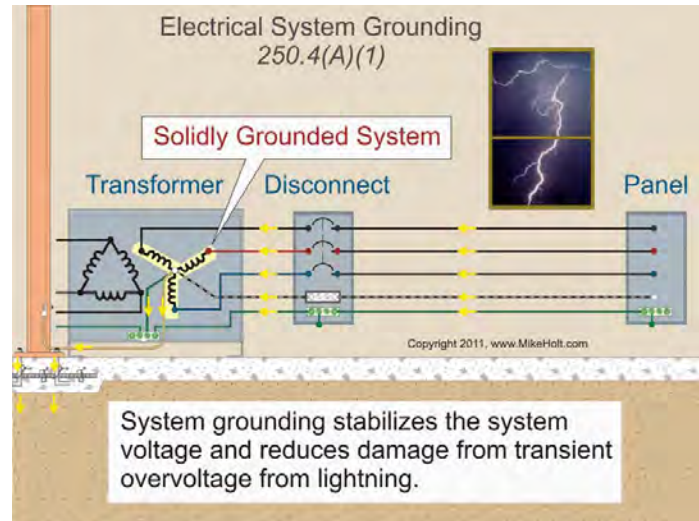

Figure 250-7

Note: An important consideration for limiting imposed voltage is to remember that grounding electrode conductors shouldn't be any longer than necessary and unnecessary bends and loops should be avoided. **Figure 250-8**

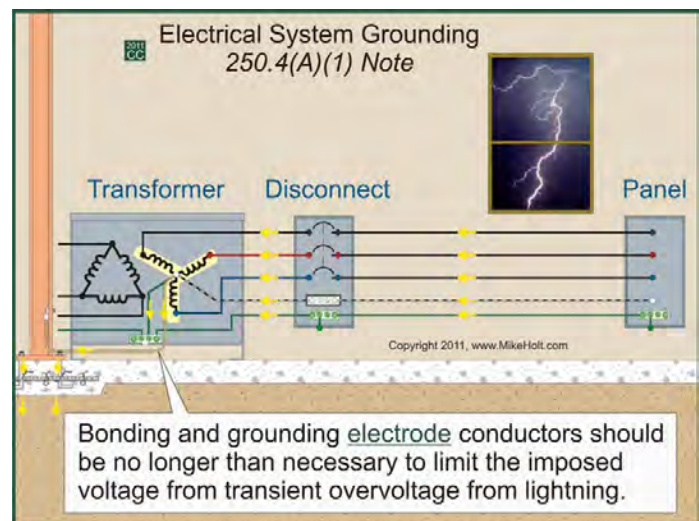

Figure 250-8

(2) Equipment Grounding. Metal parts of electrical equipment are grounded (connected to the earth) to reduce induced voltage on metal parts from exterior lightning so as to prevent fires from an arc within the building/structure. **Figure 250–9**

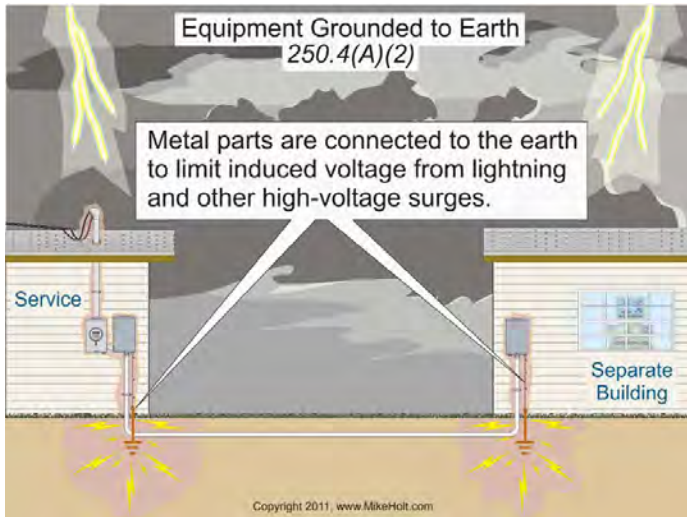

Figure 250–9

DANGER: Failure to ground the metal parts can result in high voltage on metal parts from an indirect lightning strike to seek a path to the earth within the building—possibly resulting in a fire and/or electric shock. **Figure 250–10**

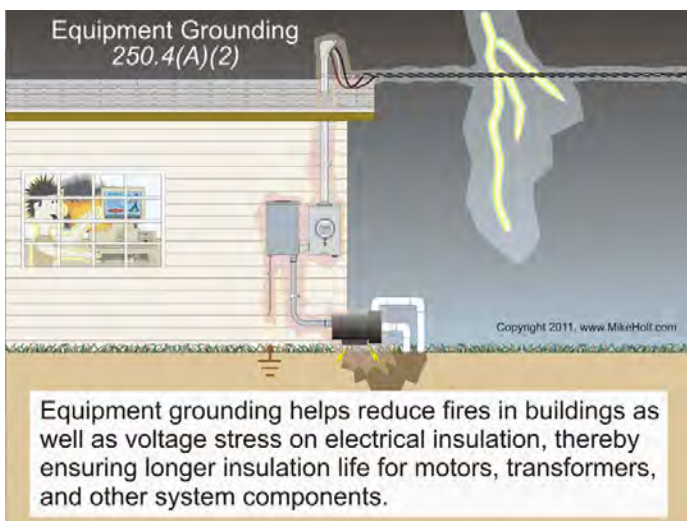

Figure 250–10

Author's Comment: Grounding metal parts helps drain off static electricity charges before flashover potential is reached. Static grounding is often used in areas where the discharge (arcing) of the voltage buildup (static) can cause dangerous or undesirable conditions [500.4 Note 3].

DANGER: Because the contact resistance of an electrode to the earth is so high, very little fault current returns to the power supply if the earth is the only fault current return path. Result—the circuit overcurrent device won't open and clear the ground fault, and all metal parts associated with the electrical installation, metal piping, and structural building steel will become and remain energized. **Figure 250–11**

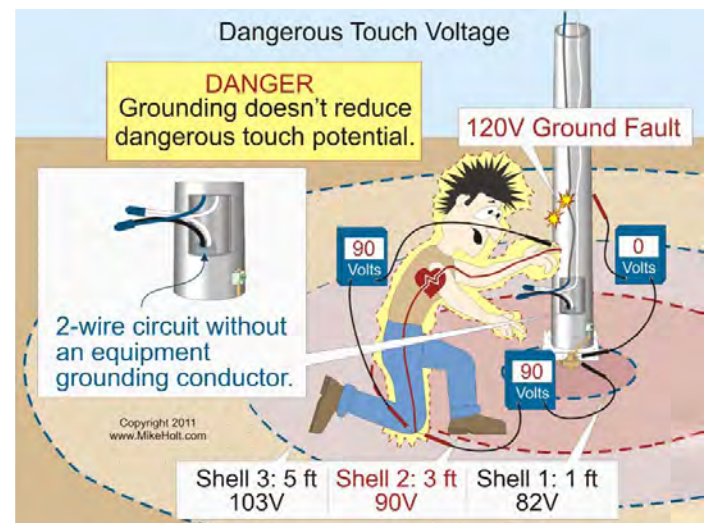

Figure 250–11

(3) Equipment Bonding. Metal parts of electrical raceways, cables, enclosures, and equipment must be connected to the supply source via the effective ground-fault current path. **Figures 250–12 and 250–13**

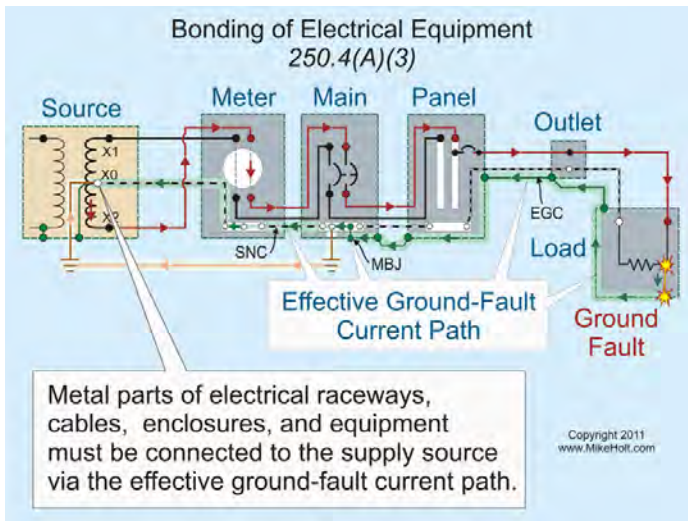

Figure 250-12

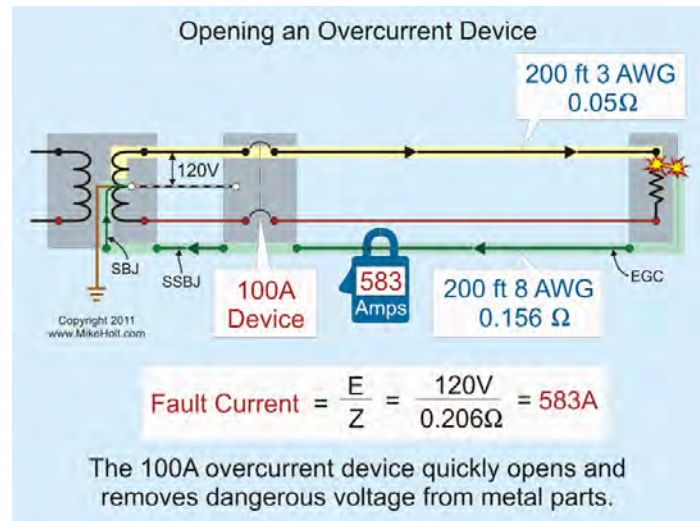

Figure 250-14

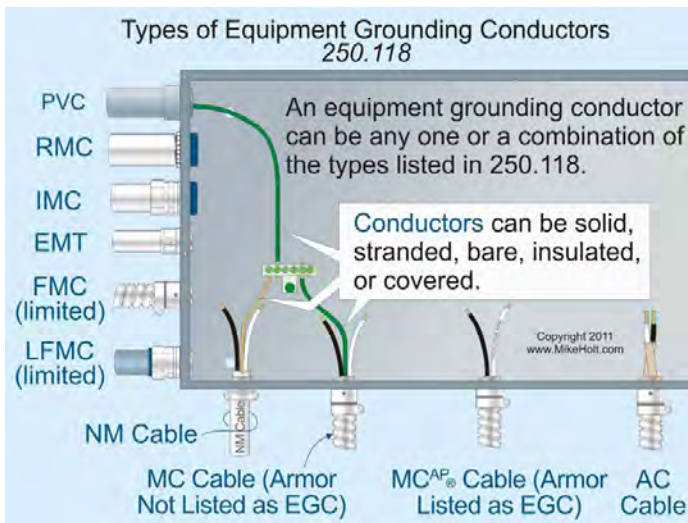

Figure 250-13

Author's Comments:

- To quickly remove dangerous touch voltage on metal parts from a ground fault, the fault current path must have sufficiently low impedance to the source so that fault current will quickly rise to a level that will open the branch-circuit overcurrent device. **Figure 250-14**

- The time it takes for an overcurrent device to open is inversely proportional to the magnitude of the fault current. This means the higher the ground-fault current value, the less time it will take for the overcurrent device to open and clear the fault. For example, a 20A circuit with an overload of 40A (two times the 20A rating) takes 25 to 150 seconds to open the overcurrent device. At 100A (five times the 20A rating) the 20A breaker trips in 5 to 20 seconds. **Figure 250-15**

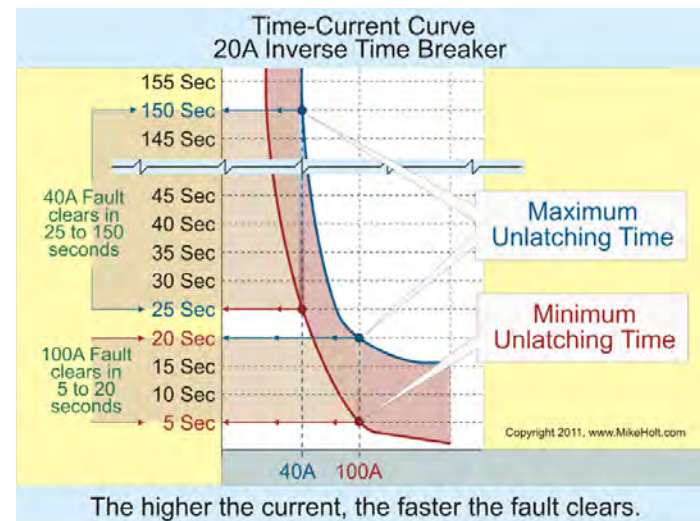

Figure 250-15

(4) Bonding Conductive Materials. Electrically conductive materials such as metal water piping systems, metal sprinkler piping, metal gas piping, and other metal-piping systems, as well as exposed structural steel members likely to become energized, must be connected to the supply source via an equipment grounding conductor of a type recognized in 250.118. **Figure 250–16**

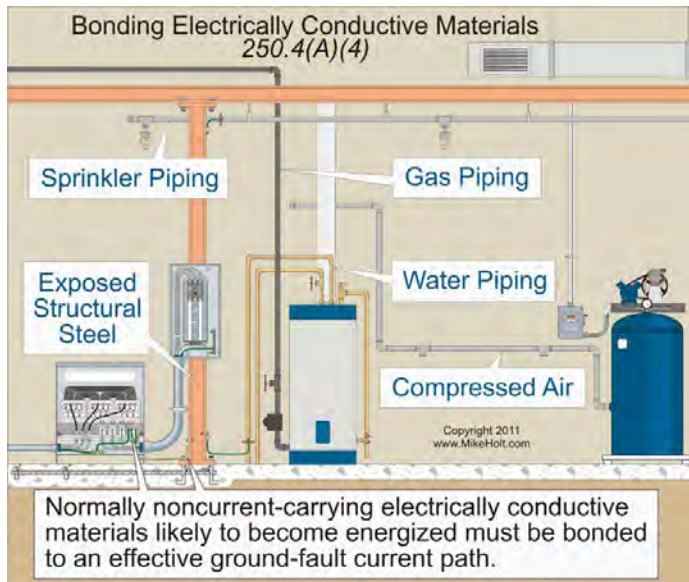

Figure 250–16

Author’s Comment: The phrase “likely to become energized” is subject to interpretation by the authority having jurisdiction.

(5) Effective Ground-Fault Current Path. Metal parts of electrical raceways, cables, enclosures, or equipment must be bonded together and to the supply system in a manner that creates a low-impedance path for ground-fault current that facilitates the operation of the circuit overcurrent device. **Figure 250–17**

Author’s Comment: To ensure a low-impedance ground-fault current path, all circuit conductors must be grouped together in the same raceway, cable, or trench [300.3(B), 300.5(I), and 300.20(A)]. **Figure 250–18**

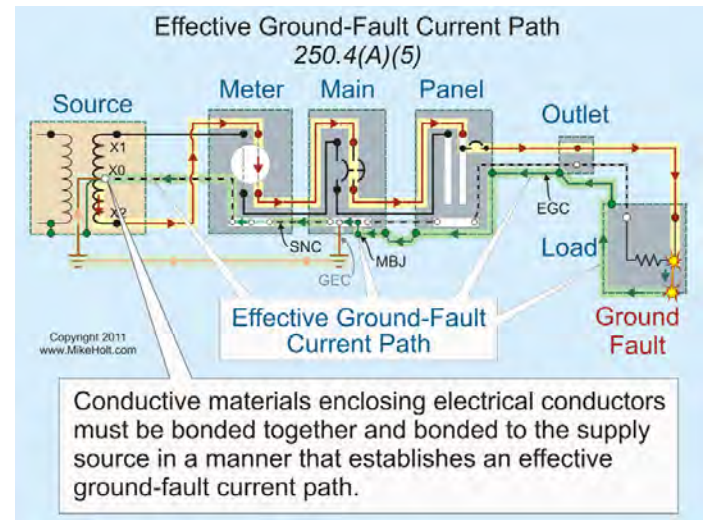

Figure 250–17

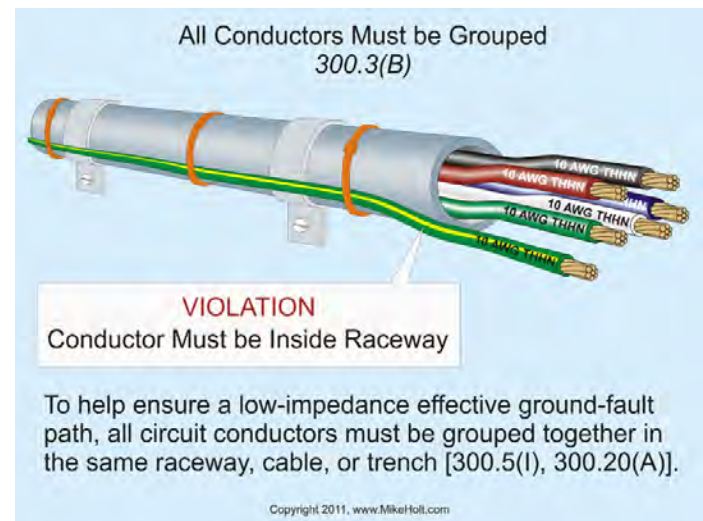

Figure 250–18

Because the earth isn’t suitable to serve as the required effective ground-fault current path, an equipment grounding conductor is required to be installed with all circuits. **Figure 250–19**

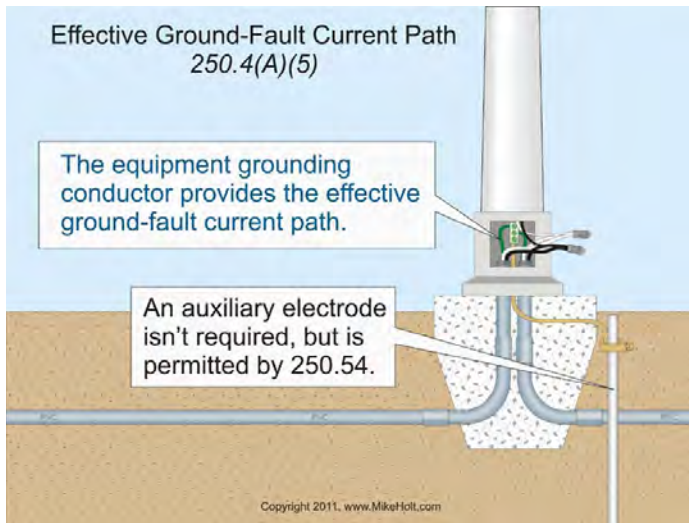

Figure 250-19

Question: What's the maximum fault current that can flow through the earth to the power supply from a 120V ground fault to metal parts of a light pole that's grounded (connected to the earth) via a ground rod having a contact resistance to the earth of 25 ohms? **Figure 250-20**

- (a) 4.80A (b) 20A (c) 40A (d) 100A

Answer: (a) 4.80A

$$I = E/R$$

$$I = 120V/25 \text{ ohms}$$

$$I = 4.80A$$

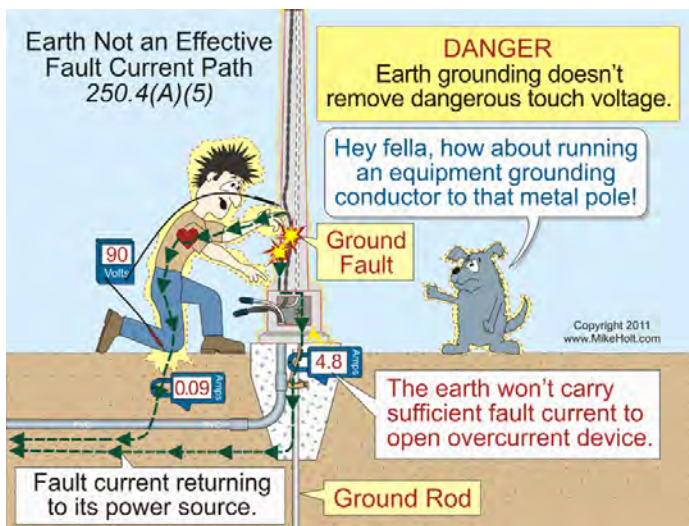

Figure 250-20

DANGER: Because the contact resistance of an electrode to the earth is so high, very little fault current returns to the power supply if the earth is the only fault current return path. Result—the circuit overcurrent device won't open and all metal parts associated with the electrical installation, metal piping, and structural building steel will become and remain energized. **Figure 250-21**

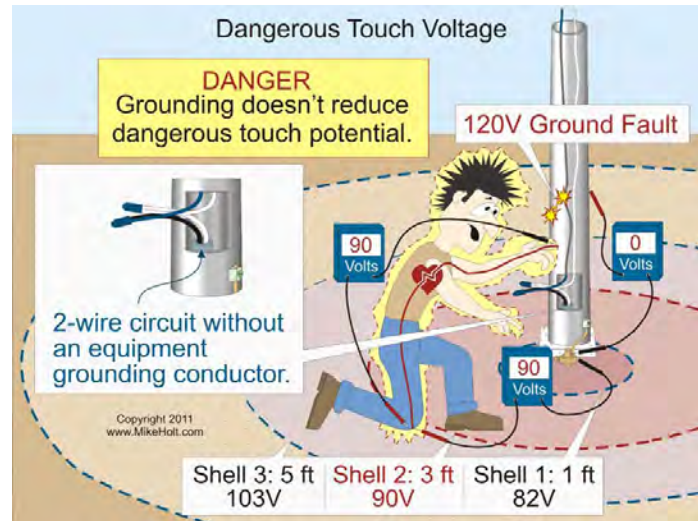

Figure 250-21

EARTH SHELLS

According to ANSI/IEEE 142, *Recommended Practice for Grounding of Industrial and Commercial Power Systems* (Green Book) [4.1.1], the resistance of the soil outward from a ground rod is equal to the sum of the series resistances of the earth shells. The shell nearest the rod has the highest resistance and each successive shell has progressively larger areas and progressively lower resistances. Don't be concerned if you don't understand this statement; just review the table below. **Figure 250-22**

Distance from Rod	Soil Contact Resistance
1 ft (Shell 1)	68% of total contact resistance
3 ft (Shells 1 and 2)	75% of total contact resistance
5 ft (Shells 1, 2, and 3)	86% of total contact resistance

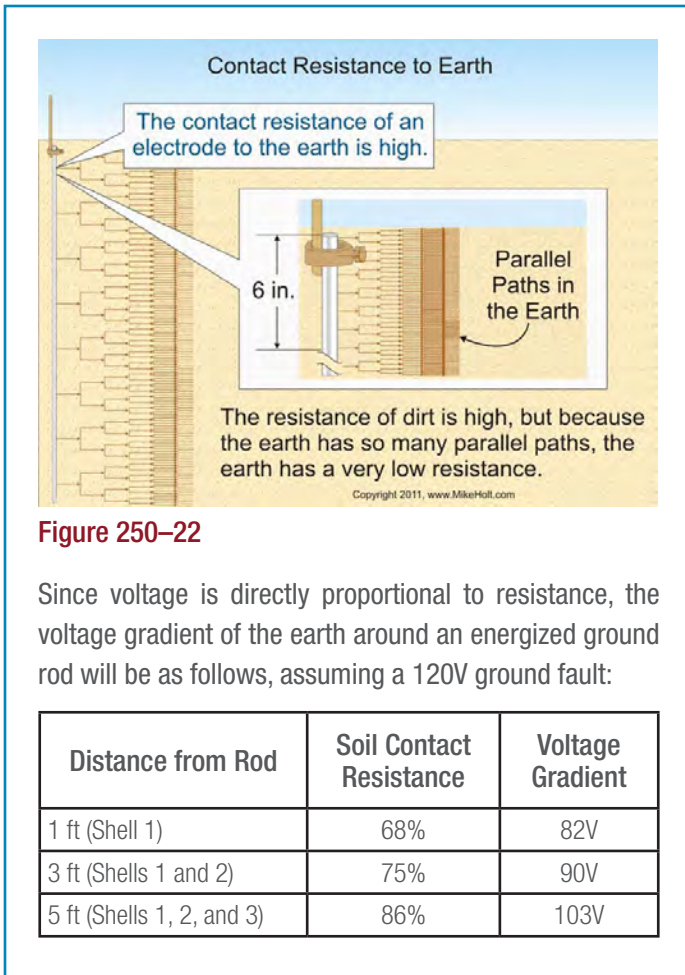

Figure 250-22

Since voltage is directly proportional to resistance, the voltage gradient of the earth around an energized ground rod will be as follows, assuming a 120V ground fault:

Distance from Rod	Soil Contact Resistance	Voltage Gradient
1 ft (Shell 1)	68%	82V
3 ft (Shells 1 and 2)	75%	90V
5 ft (Shells 1, 2, and 3)	86%	103V

(B) Ungrounded Systems.

Author's Comment: Ungrounded systems are those systems with no connection to the ground or to a conductive body that extends the ground connection [Article 100].

Figure 250-23

(1) Equipment Grounding. Metal parts of electrical equipment are grounded (connected to the earth) to reduce induced voltage on metal parts from exterior lightning so as to prevent fires from an arc within the building/structure. **Figure 250-24**

Author's Comment: Grounding metal parts helps drain off static electricity charges before an electric arc takes place (flashover potential). Static grounding is often used in areas where the discharge (arcing) of the voltage buildup (static) can cause dangerous or undesirable conditions [500.4 Note 3].

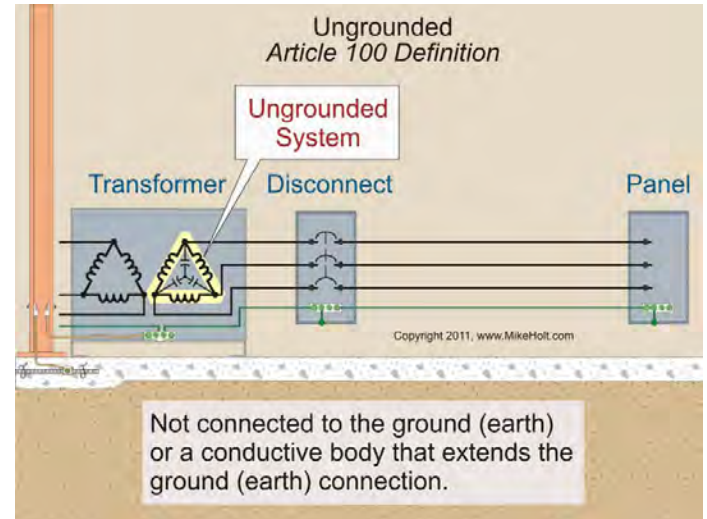

Figure 250-23

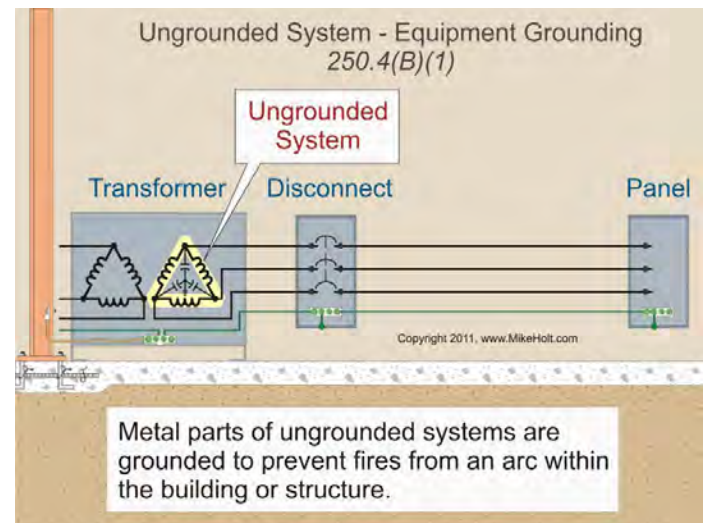

Figure 250-24

CAUTION: Connecting metal parts to the earth (grounding) serves no purpose in electrical shock protection.

(2) Equipment Bonding. Metal parts of electrical raceways, cables, enclosures, or equipment must be bonded together in a manner that creates a low-impedance path for ground-fault current to facilitate the operation of the circuit overcurrent device.

The fault current path must be capable of safely carrying the maximum ground-fault current likely to be imposed on it from any point on the wiring system where a ground fault may occur to the electrical supply source.

(3) Bonding Conductive Materials. Conductive materials such as metal water piping systems, metal sprinkler piping, metal gas piping, and other metal-piping systems, as well as exposed structural steel members likely to become energized must be bonded together in a manner that creates a low-impedance fault current path that's capable of carrying the maximum fault current likely to be imposed on it. **Figure 250–25**

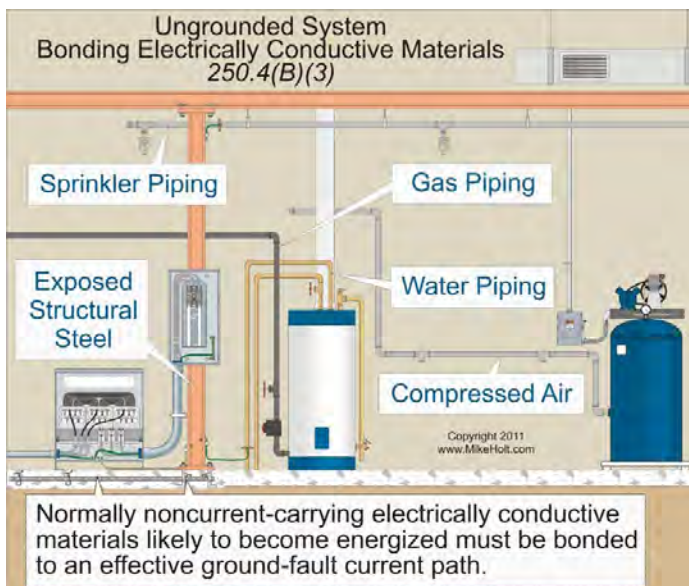

Figure 250–25

Author's Comment: The phrase "likely to become energized" is subject to interpretation by the authority having jurisdiction.

(4) Fault Current Path. Electrical equipment, wiring, and other electrically conductive material likely to become energized must be installed in a manner that creates a low-impedance fault current path to facilitate the operation of overcurrent devices should a second ground fault from a different phase occur. **Figure 250–26**

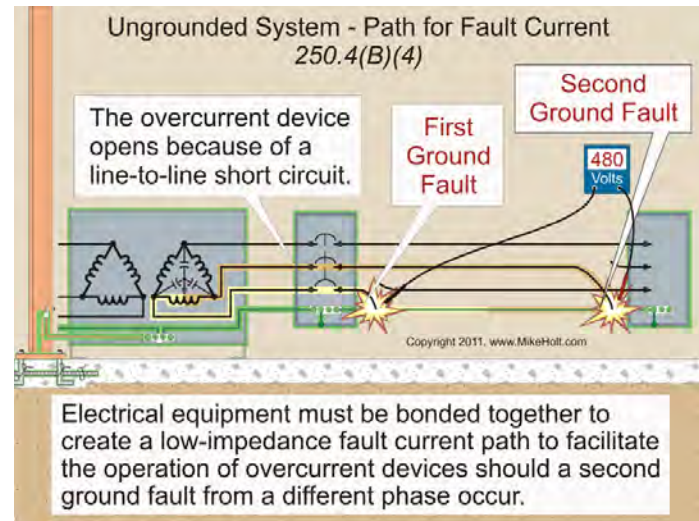

Figure 250–26

Author's Comment: A single ground fault can't be cleared on an ungrounded system because there's no low-impedance fault current path to the power source. The first ground fault simply grounds the previously ungrounded system. However, a second ground fault on a different phase results in a line-to-line short circuit between the two ground faults. The conductive path, between the ground faults, provides the low-impedance fault current path necessary so the overcurrent device will open.

250.6 Objectionable Current.

(A) Preventing Objectionable Current. To prevent a fire, electric shock, or improper operation of circuit overcurrent devices or electronic equipment, electrical systems and equipment must be installed in a manner that prevents objectionable neutral current from flowing on metal parts.

(C) Temporary Currents Not Classified as Objectionable Currents. Temporary currents from [abnormal](#) conditions, such as ground faults, aren't to be classified as objectionable current. **Figure 250–27**

(D) Limitations to Permissible Alterations. Currents that introduce noise or data errors in electronic equipment are not considered objectionable currents for the purposes of this section. Circuits that supply electronic equipment must be connected to an equipment grounding conductor.